



DBK6267 & DBK6267LX

1962-67 X-BODY & NOVA

DBK6472 & DBK6472LX

1967-69 F-BODY, 1964-72 A-BODY, X-BODY 1968-74

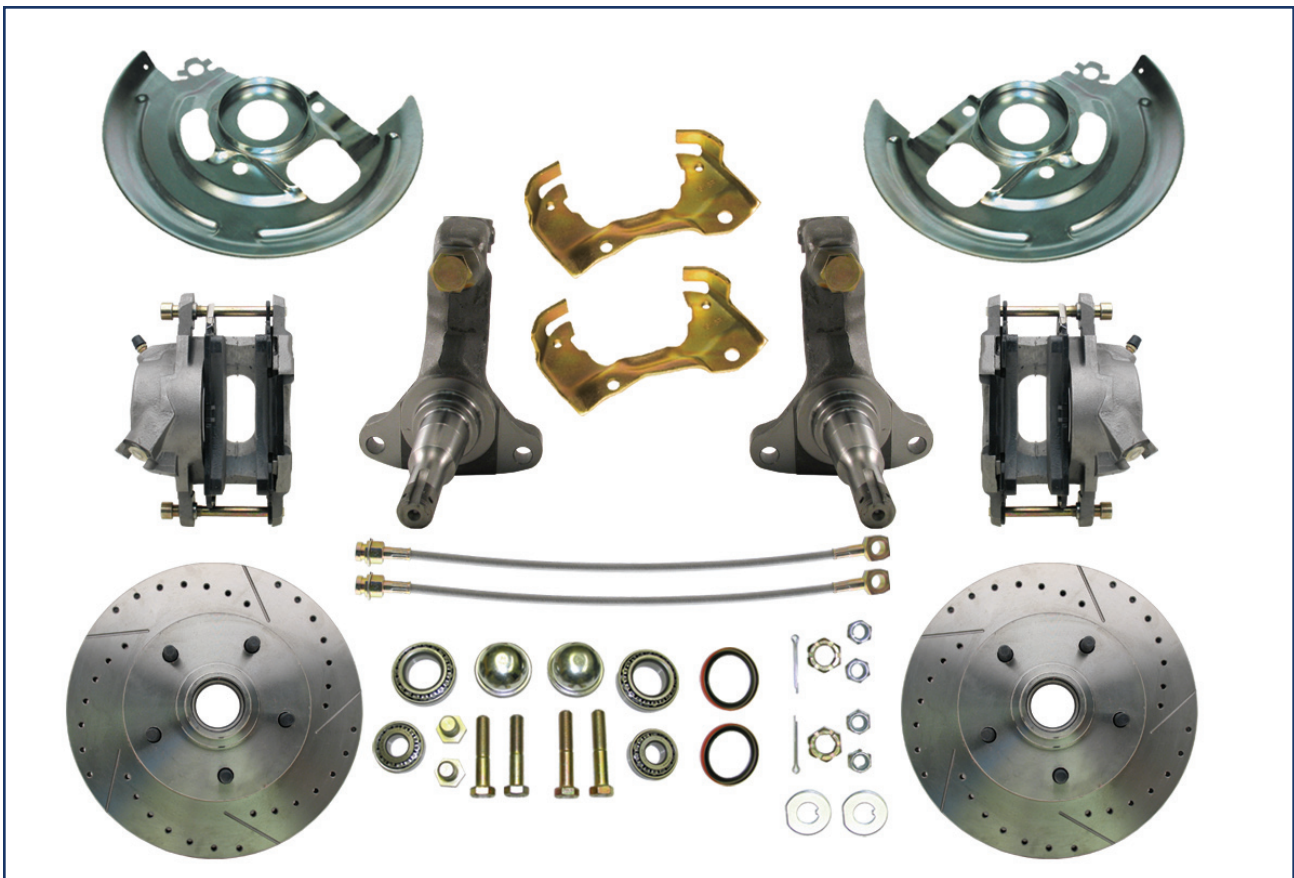

HIGH PERFORMANCE LX KIT SHOWN. ALSO AVAILABLE IN STANDARD PERFORMANCE

INSTALLATION INSTRUCTIONS

NOTE: ALWAYS REFER TO THE VEHICLE OWNER'S MANUAL FOR CORRECT TORQUE SPECIFICATIONS WHEN INSTALLING KIT.

WARNING Proper operation of your brakes is essential for your safety and the safety of others. Any brake service should be performed **ONLY** by persons experienced in the installation and proper operation of brake systems. It is the responsibility of the person installing any brake component or kit to determine the suitability of the component or kit for the particular application. After installation, and before operating your vehicle, be sure to test the function of the brakes under controlled conditions. **DO NOT DRIVE WITH UNTESTED BRAKES!**

IMPORTANT Take time to read all the literature that came with this kit. Before beginning installation check the provided list of parts against what you received to ensure that all parts are present. While this kit was designed to make the process of changing brake parts as simple as possible, **NOTE: WITH SOME KITS IT MAY BE NECESSARY TO MAKE MINOR CHANGES TO YOUR CAR! READ ALL WARRANTY DISCLAIMERS AND RETURN POLICIES INCLUDED IN THIS KIT PRIOR TO INSTALLATION!**

NOTE Always utilize safety restraints when operating the vehicle. The installation of disc brakes will require the use of 15" wheels. Any attempt to install disc brake with a 14" wheel will be the customer's responsibility.

NOTE This kit is an aftermarket solution. It is not intended to be a direct installation or OEM replacement. Due to changes in production in certain years, your car may require modifications beyond these instructions for this kit to install properly.

INSTALLATION INSTRUCTIONS

| PARTS INCLUDED WITH THIS KIT: | | |
|---|-------------------------------|-----------------|
| PART # | DESCRIPTION | QUANTITY |
| 3966151 | Spindle | 2 |
| 3966155 | Caliper Bracket Set L/R | 1 Set |
| 5514 | Rotor | 2 |
| 4039 | Right Caliper | 1 |
| 4040 | Left Caliper | 1 |
| D52 | Brake Pads (L/R) | 1 Set |
| HSDBK 7/16 | Rubber Brake Hose | 2 |
| BP151 | Backing Plate Set (L/R) | 1 Set |
| A6 | Inner Bearing set | 1 Set |
| A2 | Outer Bearing Set | 1 Set |
| HWK6472 | Hardware Kit | 1 Kit |
| 3966151-BOLT | Spindle Bolt | 2 |
| PERFORMANCE UPGRADE PARTS: | | |
| 5514 LX/RX | Drilled & Slotted Rotor | 2 |
| HSDBKSS-7/16 | Braided Stainless Steel Hose | 2 |
| OPTIONAL PARTS (NOT INCLUDED WITH BASIC KIT, AVAILABLE FOR SEPARATE PURCHASE): | | |
| | Power Booster (if Nova PB9029 | |
| | Master Cylinder | |
| | Proportioning Valve Kit | |
| | Vacuum Hose & Fittings | |
| | | |

PREPARING YOUR VEHICLE TO INSTALL YOUR BRAKE SYSTEM UPGRADE

1. Rack the vehicle.
2. If you don't have a rack, then you must take extra safety precautions.
3. Choose a firmly packed and level ground to jack up the vehicle.
4. Chock the rear wheels.
5. Jack the vehicle up and support it with jack stands and secure the pins.
6. Set the parking brake and put the transmission in park if automatic, reverse if manual transmission.
7. The front wheels should be allowed to free hang to relieve tension on the coil springs.

IMPORTANT NEVER rely on jacks to support a vehicle! Always test the steadiness of your stands that are supporting the vehicle before attempting to work on a raised vehicle!

PREPARING YOUR PARTS

1. Locate the spindles and the inner wheel bearings. In order to install the inner bearings on new spindles, often you must remove .0004" from the inner bearing seating diameter. This can be accomplished with 240 grit emery paper and a rotary sanding motion on the spindle. Be sure to sand around the radius of the spindle which avoids flat spots. Continue this operation until the inner bearings can be slid onto the spindle without binding. Remember to use brake parts cleaner to keep all surfaces free of debris. Also use a lubricant such as bearing grease to ease them on. Do not grind or file on the spindle!
2. Pack all bearings with hi-temp wheel bearing grease. A bearing packing tool is ideal for the job. (See Figure 1)
3. Adhere the brake pads into place using disc brake quiet and bend outer brake tabs over calipers accordingly. Let them cure!
4. Mate up each threaded nut with its' designated bolt or threaded surface.
5. Group your kit parts to speed up the installation.
6. Check your quantity of components versus the items list.



FIGURE. 1

COMPONENTS TO INSPECT, REPLACE OR UPGRADE DURING INSTALLATION OF DISC CONVERSION KITS

| | | |
|----------------------------|-----------------------------|--|
| Tie rod ends and nuts | Adjustment sleeves | Control arm shafts, mounting bolts, & nuts |
| Control Arms | Idler arm and nut | Pitman Arm and nut |
| Upper Ball Joints and nuts | Lower Ball Joints and nuts | Shocks and hardware |
| Residual valves | Metering valves | Proportioning valves |
| Brake lines | Stainless steel brake lines | Stainless steel hardware |

SUGGESTIONS:

- » Take the time to identify any suspect parts that are not included in this kit.
- » Consider making upgrades such as converting to polyurethane bushings, performance shocks, tubular a-arms, etc.
- » Plan any Installation (s) of replacement parts during the various stages of the drum to disc conversion process.

| | | | |
|---------------------------------------|---------------------------------|------------------|----------------------|
| Wheel bearing seal driver | Drum brake tool | Flare wrench set | Wheel chocks |
| 3/8" ratchet drive set | 3/8" Allen wrench or socket | Jack stands | Brake spring pliers |
| Box end wrench set | Ball joint fork | Tire iron | Brake bleeder wrench |
| Pliers | Screwdriver | Snips | Grease gun |
| Universal Bearing Packer 555-W1218 | Line bending tool 555-80086 | Disc brake quiet | Wheel bearing grease |
| Ball pein hammer | Disc brake pad spreader tool | Brake Fluid | Brake cleaner |
| Caliper slide grease | Hand cleaner | | |

INSTRUCTIONS

1. If you are performing the installation with a jack, be sure that the parking brake is set and that the rear wheels are chocked. Support the front of the vehicle with jack stands. Never work on sloping ground.
2. If you are using a lift, raise the vehicle to a comfortable working height.
3. Remove the front wheels.
4. At this point, be sure to place the proper support under the lower control arm. Failure to do so will allow the coil spring to blow out when the spindle is removed which could result in serious injury and damage to the vehicle.
5. Utilizing a mallet and screwdriver, remove the brake hose clip at the frame bracket by tapping it loose. Disconnect the brake hose from the hard line using the appropriate flare wrenches.
6. Locate the ball joint at the tie rod end and the steering arm. Remove the cotter pin and loosen the ball joint nut approximately 1/2 off. This allows for a controlled , separation of the tie rod end and the steering arm. Place the ball joint fork between the steering arm and the ball joint. Strike the fork with a mallet until the steering are and ball joint separate. Remove the ball joint nut.
7. Repeat the process described in step 6 for the lower and upper ball joint at the spindle. Place the ball joint fork between the spindle and the ball joint.
8. Slowly lower the support and remove the drum brake assembly as a unit.
9. Inspect the ball joints for signs of excessive wear and check to see if the rubber boot is torn. If the ball joint wobbles excessively or is worn, now is the time for replacement. Clean the ball joints with a rag.
10. Take the drum brake assembly to a bench to disassemble it. Remove the dust cover by twisting a screwdriver between the dust cover and the hub. Remove the cotter pin and take off the spindle nut. Save the spindle nut and the eyed washer for possible use on the disc spindle. Remove the bolts that hold the steering are to the spindle and retain the arm and the bolts for possible use on the disc spindle. (This requires removing the brake shoes which is easier with a drum brake tool.)
11. Place the disc brake spindle onto the lower ball joint. Torque the nut to the specification in the owners manual. Insert the cotter pin and bend it.

12. Raise the control arm support and repeat step 11 for the upper ball joint. Remember to use the torque specification in the owners manual.

13. The caliper bracket attaches to the spindle so that the caliper will be located toward the rear of the vehicle. This is accomplished by mounting the bracket with the ears toward the rear and the “tangs” pointing toward the out side (see Figure 2).

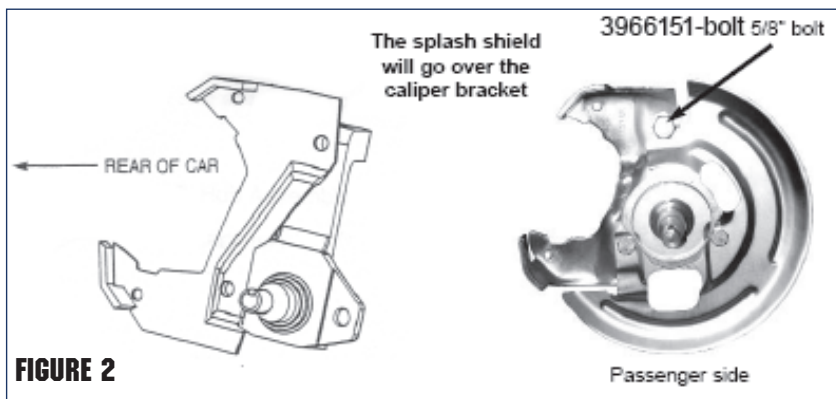

Using the 5/8” bolt supplied, attach the bracket and the splash shield to the spindle. Attach the steering arm with the supplied 1/2” bolts, using one of the bolts to attach the bracket and shield to the spindle. Torque all three bolts to the specifications in the owners manual.

14. Attach the steering arm to the tie rod. Torque the nut to the recommended specification. Install the cotter pin and bend it.

15. Check the fit of the inner and outer bearing on the spindle. If the fit is too tight, lightly sand the spindle with emery cloth until the bearings slide on easily.

16. Grease the inner and outer bearing by “packing” grease between the rollers and coating the inside and outside diameters. Be sure to use a good high temperature bearing grease.

17. Grease the inner and outer race on the inside of the rotor. Install the inner bearing into the rotor. Lightly tap the grease seal into place with a mallet until it is seated. Clean the rotor before installation with brake cleaner followed by soap and water. (Figure 3)

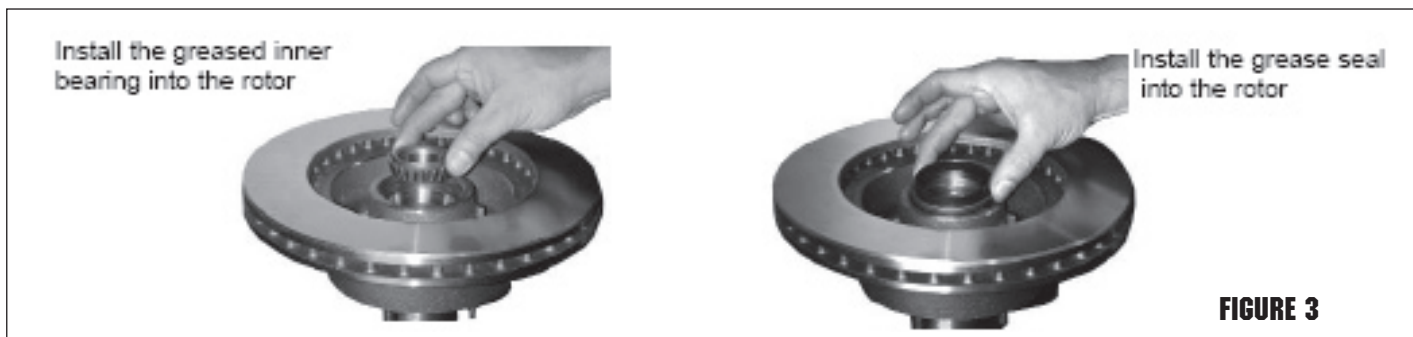

18. Grease the spindle where the bearings fit. Install the rotor onto the spindle followed by the outer bearing, the keyed washer, a new-spindle nut. Tighten the spindle nut to the specified torque and insert the cotter pin. Bend the cotter pin, snip off the excess, and install the dust cap, by tapping a socket that fits on the cap edge, or by tapping a screwdriver on the edge of the cap. Spin the rotor and check to be sure that it rotates smoothly and there is no wobble. Clean the rotor.

19. Install the loaded caliper onto the mounting bracket with the bleeder screw facing up (see Figure 4). Insert the caliper mounting bolts and torque to the recommended specifications. Spin the rotor to be sure that it rotates smoothly.

20. Install the hose onto the caliper. Be sure that the brass end of the hose is sandwiched between the two copper washers. The sequence must be: bolt - washer - hose fitting - washer - caliper. Tighten the bolt to the recommended specifications.

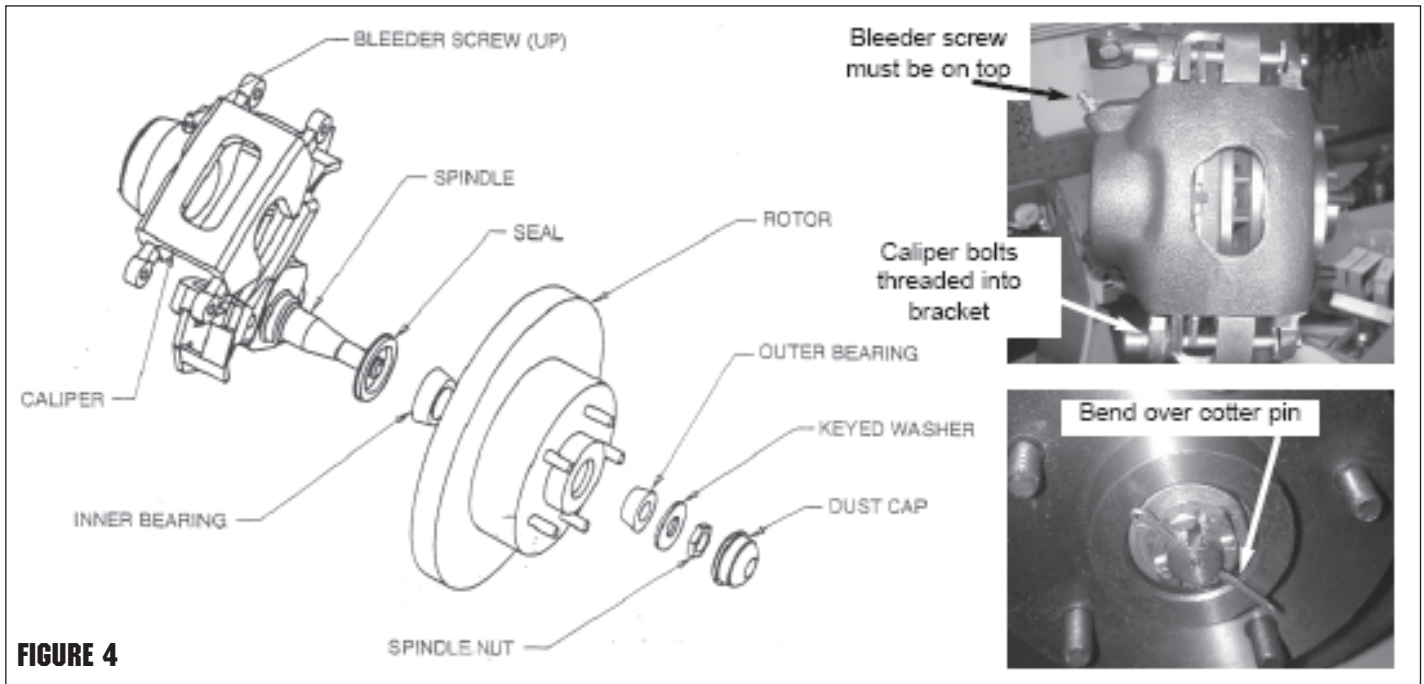

FIGURE 4

21. Using the flare wrenches, attach the other end of the hose to the hard line at the chassis. Tap the hose clip back into place with a mallet. Turn the steering assembly full right and left to be sure that the hose does not bind or twist.

22. Repeat this process for the other side and the disc portion of the conversion is complete.

BOOSTER & MASTER CYLINDER INSTALLATION (IF PURCHASED WITH KIT)

1. Disconnect the old master cylinder lines (Remember, if operating around painted surfaces, avoid brake fluid to paint contact). Remove any valves that are installed in the drum system and discard. If the vehicle has a pressure differential switch, it must also be removed. Remove the old master cylinder.
2. When changing from a manual brake system to a power system, the clevis assembly that attaches the push rod to the brake pedal must be removed and lowered one inch. If two holes are in the pedal use the lower hole for the power booster rod attachment. If only one hole exists from the manual system a second hole must be drilled one inch lower. Remove the clip and pin that attaches the clevis to the brake pedal and retain them. If the lower hole does not already exist, one must be drilled. Screw the clevis assembly onto the new push rod on the booster about 1/2".
3. Mount the booster to the fire-wall with the existing studs or bolts. Place the clevis assembly into the lower hole in the pedal and install the pin and clip.
4. Install the proper fitting into the intake manifold for vacuum. Connect the vacuum hose from the engine to the power booster. **YOU WILL NEED AT LEAST 18" VACUUM TO OPERATE A BOOSTER.**
5. Bench bleed the master cylinder with the supplied bleeder kit.
6. Install the master cylinder onto the booster.
7. Mount the combination valve to supplied bracket and attach the bracket and lines as shown in fig. 4.
8. You will now need to run two lines from the supplied combination valve to the frame. Tie the lines into the existing front and rear lines with brake line couplers. You may run two separate lines from the combination valve to each front wheel or you may plug one outlet to the front, run one line and then split it to each front wheel.

TESTING THE PROPORTIONING VALVE FOR PROPER OPERATION:

1. Use a test light by attaching a clip to a positive contact on the vehicle and touch the point of the tester to the electrical connection of the combination valve. If the light does not come on, the valve system is operation correctly and no further testing is required.
2. If the light does come on, this indicates that the pressure differential valve is stuck in the front or rear position.
3. Bleed the brake system to determine if the front or rear lines are blocked off. Set up one front wheel and one rear wheel for bleeding at the same time. Crack both bleeder screws and gently pump the pedal a few times. The blocked side will trickle fluid out when the bleeder screw is cracked and the pedal pressed. An unblocked line will squirt fluid out the bleeder.
4. The lines that are clear must be left open and the blocked lines should have the bleeder screws tight to cause pressure to build up on that side. Be sure to use the standard bleeding procedures to prevent air from entering the system.
5. Slowly press the pedal with steady pressure a number of times until the light goes out; this will center the differential valve. You may also hear a pop come from the proportioning valve. This is the metering valve returning to its equalized position. When the light goes out, close the bleeder screw.

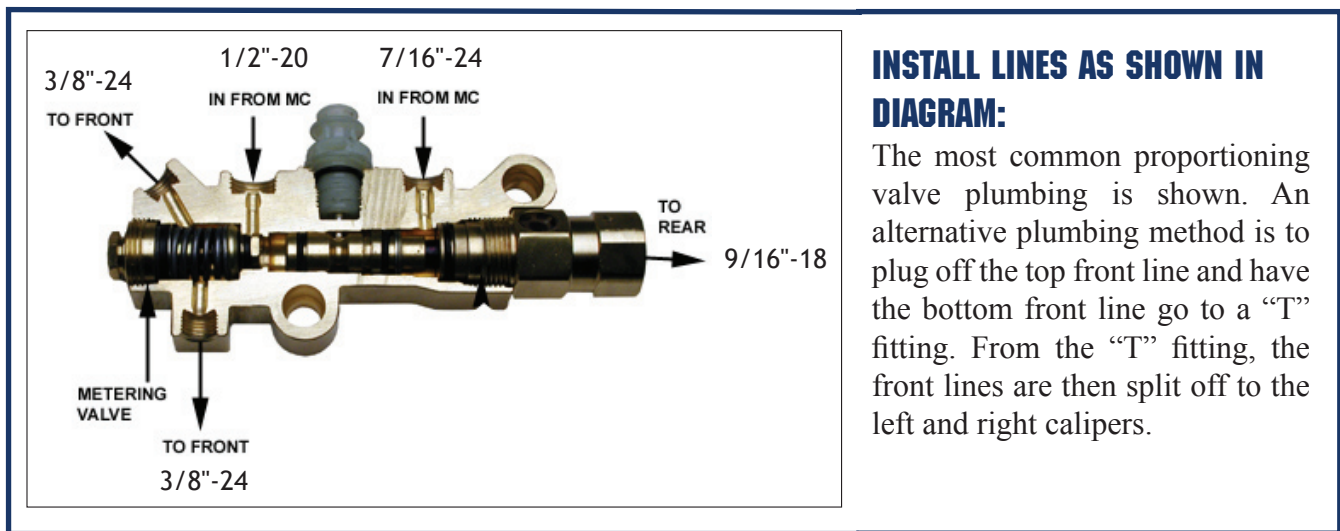

WHAT TO DO IF YOU SUSPECT YOUR BOOSTER IS NOT WORKING

It is rare that one of our kits will contain a defective power booster but if you suspect that your booster is not functioning correctly perform the following tests:

BASIC TEST

1. With the engine off depress and release the brake pedal several times to eliminate vacuum from the power section.
2. Depress the pedal and hold down with light pressure, 15 to 25 pounds.
3. Start engine.
4. If the power unit is operating the pedal will drop slightly. Less pressure will be needed to hold the pedal down.

IF BOOSTER IS NOT OPERATING (GIVING A VERY HARD PEDAL)

1. Disconnect the vacuum hose from the booster check valve and check the vacuum level at this point with the engine running with a vacuum gauge. You should have at least 18" vacuum to the booster. Anything lower will begin to give a hard pedal. If the vacuum level is below 18" you may be able to tune the engine and bring the vacuum level up to that level. If the vacuum level is around 16" the addition of a vacuum reserve canister will improve the braking. If the vacuum level is below 16" you will need to add an electric vacuum assist pump to supplement the engine vacuum.

2. If the vacuum level at the check valve is 18" check that the booster check valve is working. Disconnect the vacuum hose at the check valve and attach a piece of tubing. Blow into the valve. If air passes through the valve is defective and must be replaced. Also look into the hose attachment neck on the check valve and be sure there is no obstruction inside the valve.
3. Check your booster for a vacuum leak. With everything hooked up run the engine at moderate speed. Release the accelerator and turn the engine off. Wait 90 seconds and apply the brakes. If the brake applications are power assisted there is no leak. If there is no power assist the booster is defective and must be replaced.

IF THE BOOSTER IS OPERATING BUT YOU STILL HAVE A HARD PEDAL

1. Your combination valve may have tripped shutting off fluid flow to the front or rear brakes. This condition will produce a very hard pedal. Check that fluid passes through the valve to both the front and rear by cracking a bleeder screw and observing a good flow of fluid. If one half of the system does not have flow, re-center the valve.
2. You may have frozen rear wheel cylinders or frozen caliper pistons. If these components freeze you can get a very hard pedal.
3. Your pedal ratio may be too low. Check your pedal ratio. The pedal ratio must be in between 4:1 to 5:1. Some of the older cars that had power brakes used a ratio of almost 1:1. If you add a vacuum booster to this type of car you will have a very hard pedal. Typically we are talking about late 50's cars. Adjust ratio as necessary.
4. Your booster may be undersized for the weight of the vehicle or the bore size of the master. If you try to use a small diameter booster such as a 7" street rod booster for a heavy car you will get a very hard pedal. Compounding the problem is an attempt to use a large bore master (1-1/4" or larger) on a small booster.

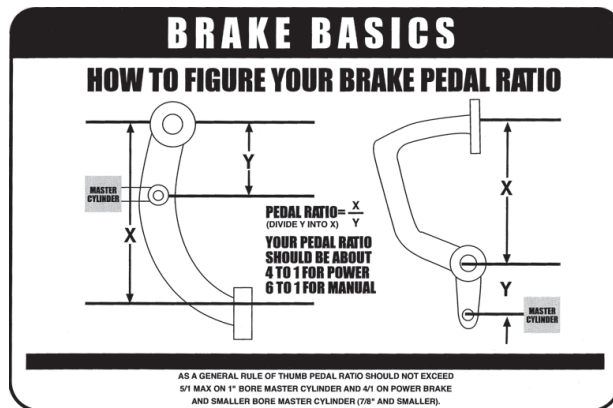

IF YOUR BRAKE PEDAL IS VERY SENSITIVE AND THE BRAKES GRAB

1. Your pedal ratio may be too high. Power brakes will require a 4:1 to 5:1 ratio. If your ratio is around 6:1 you are getting too much mechanical advantage making the brakes extremely sensitive. Adjust the ratio to correct level.
2. The booster may be too large for the weight of the vehicle. Lightweight vehicles with large boosters give you "touchy brakes". This effect may be dampened somewhat by going to a larger bore master.
3. Too large a booster for front drum brakes. Drum brakes do not require as much pressure as disc brakes (500 psi vs. 1,000 psi). If your booster is very large (11") and you have drum brakes you are over-boosted. Do a pressure test to determine what you have.
4. The booster has a cracked internal hub. When there is a crack in the phenolic hub inside the booster it will be either totally on or totally off. Any slight pressure to the pedal will cause the brakes to lock up. The booster must be replaced.

TEN REASONS FOR A POOR BRAKE PEDAL

| CAUSE | REASON |
|---|---|
| Bleeder screws on calipers not on top. | The bleeder screws on calipers must be at the 12:00 position on the caliper to allow all the air to escape during bleeding. A very common mistake installers will make is to reverse the side the caliper goes on giving you a situation where the caliper bleeder screw is facing down. It's also common to use the wrong caliper on a bolt on disc kit giving a situation where the bleeder hole is shifted from the 12:00 position producing a pocket of air at the top of the caliper bore which can not be dislodged. Check your bleeder hole orientation. |
| A defective master cylinder which does not hold pressure. | If brake fluid bypasses a pressure seal on a master cylinder you will get a pedal that fades. To test for this obtain two inverted flare plugs at an auto parts store and plug both master cylinder outlets. Try your pedal. If the pedal is high and firm the master is good. If the pedal fades the master is bad. Replace master as necessary. |
| No residual pressure valve to rear drums. | Drum brakes require the use of a 10 Ib residual pressure valve in the line. This residual pressure counter balances the drum brake spring tension keeping the shoes close to the drums. This results in a higher firmer pedal. You can test this by clamping off the rear hose removing the rear drums from the system. Now test your pedal. If the pedal gets better you will need to splice a 10 Ib residual pressure valve into the rear line. |
| Hard line that loops up. | Hard brake line that loops up and then back down will tend to trap air. It doesn't take much air to cause problems so check your lines carefully. |
| Incorrect master cylinder. | If the bore size of the master cylinder is too small for the fluid requirements of the system you will get a very poor pedal. This will happen most frequently with four piston calipers and with four wheel disc brakes. The only solution for this is to install a larger bore master cylinder or a true four wheel disc master. |
| Incorrectly bled or adjusted rear calipers. | Rear calipers that have an internal parking brake with a lever can be troublesome. These calipers must be adjusted so that the piston is moved out and the pads are close to the rotor. If this initial adjustment is not made the pistons will travel outward during activation but no squeezing of the rotor will occur. This can be checked by clamping off the rear hoses and checking if the pedal gets better. Adjust as necessary. |
| Incorrect booster pin length. | The booster pin that pushes on the master cylinder must almost be touching the master cylinder piston face. A gap larger than 1/32" will begin to introduce a spongy pedal. Adjust as necessary. |
| Silicone brake fluid. | While silicone fluid is great because it does not attack paint it also aerates very easily and can give a spongy pedal. |
| Rear wheel cylinders too large. | Rear drum wheel cylinders that are too large will give a poor pedal. Check as in step six above. |
| Loose front wheel bearings. | Loose front wheel bearings will cause rotor wobble. This will cause the caliper pistons to retract too far into the caliper giving a spongy pedal every time you hit the brakes. Check and adjust as necessary. |

UNIVERSAL FRONT DISC BRAKE CHECKLIST

| | |
|--|--|
| | Spindle properly secured to ball joints and tie rods with castle nut and cotter pin. |
| | All mounting bolts properly tightened. |
| | Wheel bearings properly packed with grease. |
| | Inner bearing must be installed before grease seal. |
| | Rotor I bearings slide onto spindle with ease. |
| | Washer, castle nut properly torqued and cotter pin installed. |
| | Calipers installed and properly torqued. |
| | Spin rotor and check for any interference. (If any interference is found, resolve problem before driving vehicle.) |
| | Flex lines are properly installed with no interference. |
| | Power booster (if applicable) installed properly. |
| | Master cylinder bench bled according to the instructions. |
| | All brake lines are properly tightened and free of leaks. |
| | Turn wheels lock to lock and check for any interference. |
| | Place wheel onto vehicle and spin the wheel to make sure there is no interference between the brakes and wheel. |

UNIVERSAL REAR DISC BRAKE CHECKLIST

| | |
|--|---|
| | All bolts on base bracket properly tightened. |
| | All caliper mounting bolts properly tightened. |
| | Rotor slides onto axle with ease. |
| | No interference with rotor and any other parts (splash shield, brackets, etc.). |
| | Caliper is centered over the rotor (because of difference in axle lengths, you may have to shim caliper in or out). |
| | No interference with caliper and rotor. |
| | All brake lines are tight with no leaks. |
| | Parking brake is properly adjusted and not dragging, with vehicle on ground. |
| | Adjustable proportioning valve installed (if applicable). |
| | Distribution block modification made (if applicable). |
| | Brake system properly bled. |

IMPORTANT WITH EVERY NEW SET OF ROTORS AND PADS, YOU SHOULD GIVE YOUR VEHICLE 200 - 250 MILES OF EASY DRIVING TO PROPERLY SEAT THE PADS TO THE ROTORS. DO NOT TAKE THE VEHICLE UP TO 60 MPH AND JAM ON THE BRAKES BEFORE THE FIRST 200 - 250 MILE BREAK IN PERIOD IS OVER, OR YOU WILL GLAZE THE PADS AND ROTORS.