







WARNING Proper operation of your brakes is essential for your safety and the safety of others. Any brake service should be performed **ONLY** by persons experienced in the installation and proper operation of brake systems. It is the responsibility of the person installing any brake component or kit to determine the suitability of the component or kit for the particular application. After installation, and before operating your vehicle, be sure to test the function of the brakes under controlled conditions. **DO NOT DRIVE WITH UNTESTED BRAKES!**



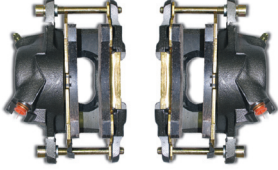

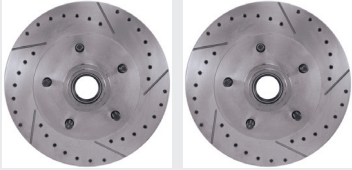
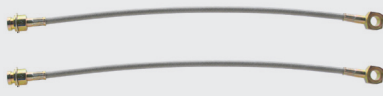

IMPORTANT Take time to read all the literature that came with this kit. Before beginning installation check the provided list of parts against what you received to ensure that all parts are present. While this kit was designed to make the process of changing brake parts as simple as possible, **NOTE: WITH SOME KITS IT MAY BE NECESSARY TO MAKE MINOR CHANGES TO YOUR CAR! READ ALL WARRANTY DISCLAIMERS AND RETURN POLICIES INCLUDED IN THIS KIT PRIOR TO INSTALLATION!**

NOTE Always utilize safety restraints when operating the vehicle. The installation of disc brakes will require the use of 15" wheels. Any attempt to install disc brake with a 14" wheel will be the customer's responsibility.

PARTS INCLUDED WITH THIS KIT

	 <p>Part # CB6568 Caliper Bracket</p>
 <p>Part # A6 - Inner Bearings A2 - Outer Bearings 7934 - Seals</p>	 <p>Part # 4039/4040 Calipers loaded with pads</p>
 <p>Part # HWK6568 Hardware Kit</p>	 <p>Part # VH Check Valve Hose</p>
 <p>Part # 5514L/R Standard Rotors</p>	 <p>Part # HSDBK-10mm brake lines</p>
 <p>Part # 5514LX/RX Drilled & Slotted Rotors (takes place of 5514 in HP kit)</p>	 <p>Part # HSDBKSS-10mm stainless steel braided lines (takes place of HS- DBK in HP kit)</p>

OPTIONAL ACCESSORIES

 <p>This kit requires the use of your own spindle. There is NO spindle supplied with this kit.</p>	 <p>Part # Power Booster. There are many compatible boosters available from MBM.</p>
 <p>Part # APV-1 Adjustable Proportioning valve (Optional. Not supplied with this kit. Available from your MBM dealer)</p>	 <p>Part # PV-2 or PV-4 Proportioning valve. (Optional but recommended. Available from your MBM dealer.)</p>
 <p>Part # 650 Booster Bracket</p>	 <p>Part # 1321H Master Cylinder</p>

PREPARING YOUR VEHICLE TO INSTALL YOUR BRAKE SYSTEM UPGRADE

1. Rack the vehicle.
2. If you don't have a rack, then you must take extra safety precautions.
3. Choose a firmly packed and level ground to jack up the vehicle.
4. Chock the rear wheels.
5. Jack the vehicle up and support it with jack stands and secure the pins.
6. Set the parking brake and put the transmission in park if automatic, reverse if manual transmission.
7. The front wheels should be allowed to free hang to relieve tension on the coil springs.

IMPORTANT NEVER rely on jacks to support a vehicle! Always test the steadiness of your stands that are supporting the vehicle before attempting to work on a raised vehicle!

PREPARING YOUR PARTS

1. Locate the spindles and the inner wheel bearings. In order to install the inner bearings on new spindles, often you must remove .0004" from the inner bearing seating diameter. This can be accomplished with 240 grit emery paper and a rotary sanding motion on the spindle. Be sure to sand around the radius of the spindle which avoids flat spots. Continue this operation until the inner bearings can be slid onto the spindle without binding. Remember to use brake parts cleaner to keep all surfaces free of debris. Also use a lubricant such as bearing grease to ease them on. Do not grind or file on the spindle!
2. Pack all bearings with hi-temp wheel bearing grease. A bearing packing tool is ideal for the job. (See Figure 1)
3. Adhere the brake pads into place using disc brake quiet and bend outer brake tabs over calipers accordingly. Let them cure!
4. Mate up each threaded nut with its' designated bolt or threaded surface.
5. Group your kit parts to speed up the installation.
6. Check your quantity of components versus the items list.



Universal Bearing Packer

FIGURE. 1

COMPONENTS TO INSPECT, REPLACE OR UPGRADE DURING INSTALLATION OF DISC CONVERSION KITS

Tie rod ends and nuts	Adjustment sleeves	Control arm shafts, mounting bolts, & nuts
Control Arms	Idler arm and nut	Pitman Arm and nut
Upper Ball Joints and nuts	Lower Ball Joints and nuts	Shocks and hardware
Residual valves	Metering valves	Proportioning valves
Brake lines	Stainless steel brake lines	Stainless steel hardware

SUGGESTIONS:

- » Take the time to identify any suspect parts that are not included in this kit.
- » Consider making upgrades such as converting to polyurethane bushings, performance shocks, tubular a-arms, etc.
- » Plan any Installation (s) of replacement parts during the various stages of the drum to disc conversion process.

INSTALLATION OF THE DISC BRAKE KIT REQUIRES THE USE OF THE FOLLOWING TOOLS & CHEMICALS:

Wheel bearing seal driver	Drum brake tool	Flare wrench set	Wheel chocks
3/8" ratchet drive set	3/8" Allen wrench or socket	Jack stands	Brake spring pliers
Box end wrench set	Ball joint fork	Tire iron	Brake bleeder wrench
Pliers	Screwdriver	Snips	Grease gun
Universal Bearing Packer 555-W1218	Line bending tool 555-80086	Disc brake quiet	Wheel bearing grease
Ball pein hammer	Disc brake pad spreader tool	Brake Fluid	Brake cleaner
Caliper slide grease	Hand cleaner		

INSTRUCTIONS

Unless you have securely jacked up and supported the vehicle, do not proceed to install the kit! See section called 'Preparing your vehicle to install your brake system upgrade.

AT THIS POINT YOU CAN CHOOSE ONE OF TWO METHODS:

Method 1. Remove the spindle with drums mounted as a unit, which is heavy, or ...

Method 2. You can remove the components individually.

METHOD 1. REMOVING THE UNIT AS ONE ASSEMBLY

1. Remove the wheels. Mark them Left and Right so you will not effect any tire rotation that you have ongoing. Similarly if you have directional tires, place them accordingly.
2. Remove the steering arm/tie rods from the O.E. drum spindles. Disconnect / remove the tie rod ends from the drum-spindle setup. (Put the Tie rod nuts back on the tie rods so you don't lose or contaminate them.) (See Figure 2)
3. Disconnect the brake hoses at the frame and remove them.
4. Support the drum and spindle assembly so it won't fall on you by using a transmission jack, a body brace or similar device.
5. Remove the cotter pins from the upper and lower control arms nuts and break the spindle mounting nuts free.
6. With the ball joint nuts attached, use a ball joint separator tool to separate the joints from the spindles.
7. Remember that the coil springs are loaded, so you must relieve coil spring tension as you remove the upper ball joint nut. The safest option is to use a coil spring compressor so that the assembly can be removed in a controlled, safe Method.
8. Next remove the ball joint nuts and remove the assembly from its' home between the control arms.
9. Put the ball joint nuts back on as you will need to reuse them.

METHOD 2. REMOVING THE COMPONENTS INDIVIDUALLY

1. Remove the wheels. Mark them Left and Right so you will not effect any tire rotation that you have ongoing. Similarly if you have directional tires, place them accordingly.
2. Next remove the cotter pins and spindle nut. Set these aside as extras.
3. Crack open the bleeder screws on the front wheel cylinders to allow fluid to drain so the cylinders can retract slightly.
4. Remove the drum using the drum brake tool and or screwdriver. Remember, the drums will not pull off of the shoes if the wheel adjusters are not turned to allow the shoes to retract inward towards one another.
5. Remove the brake line or hose from the wheel cylinder to the frame mounts.
6. Remove the backing plate bolts so that the whole plate can be removed with cylinder, shoes and mounting hardware in tact.
7. Brace the lower control arm.

- Remove the cotter pins from the upper and lower control arms nuts and break the spindle mounting nuts free.
- With the ball joint nuts attached, use a ball joint separator tool (See Figure 2) to separate the joints from the spindles.
- Remember that the coil springs are loaded, so you must relieve coil spring tension as you remove the upper ball joint nut. The safest option is to use a coil spring compressor (See Figure 3) so that the assembly can be removed in a controlled, safe method.
- Next remove the ball joint nuts and remove the spindle from its' home between the control arms.
- Put the ball joint nuts back on as you will need to reuse them.



FIGURE. 2



FIGURE. 3

CALIPER BRACKET & STEERING ARM INSTALLATION

- Remove caliper brackets from plastic and ready appropriate spacer and bolts. The brackets are NOT side specific, and can be used on left or right spindle.
- Install main bracket and secondary bracket to spindle as shown in figure 5. Make sure to install the spacer (figure 4) on the bolt in the top hole of the secondary bracket BETWEEN the secondary bracket and main bracket (as shown in figure 5 and figure 6).

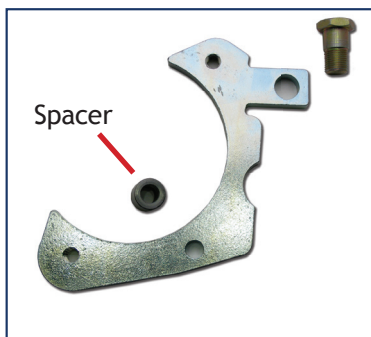

FIGURE. 4



FIGURE. 5



FIGURE. 6

SPINDLE INSTALLATION AND DISC CONVERSION

- Mount spindles to ball joints. Be mindful of LH and RH markings. Tighten the ball joint nuts, install washers and pins.
- Fasten steering control arms and or tie rod ends. Grease the ball joints until grease runs out from the rubber.
- Then tighten the steering control arms to the appropriate torque, install cotter pins, and check for smooth steering range of motion. Grease the tie rod ends until grease runs out from the rubber. (Remember that it is likely that an alignment will be needed.)
- Next test fit your inner wheel bearing onto the spindle. (See preparing your parts)
- Now it is time to prepare your rotor, install the inner wheel bearing and seal, and remember to discard the race provided with the bearing, as one is already pressed in for you (figure 7).
- Pack the bearings and the rotors with grease if this has yet to be done.



INSTALLATION INSTRUCTIONS

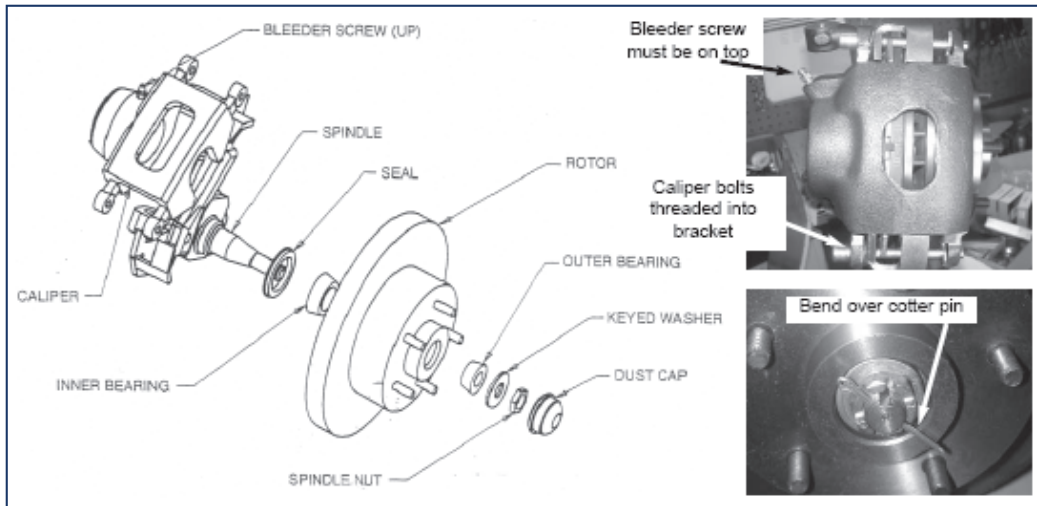

7. Press in the wheel seals using a block of wood or seal driver.
8. Install rotors and tighten down spindle nuts, add cages and install cotter pins.
9. Install grease caps after adding your final grease to the bearings.
10. Give the rotor a “test spin” and check for proper installation and true mounting.
11. Wash the protective film off of the rotors using brake parts cleaner.
12. Remove any packing material from the loaded calipers and remove the two 4-1/4” long bolts provided. Use disc brake quiet on the back of your brake pads if you have not done this already. (See preparing your parts)
13. Mount the caliper into the spindle cradle. You may need to move the two silver bolt sleeves in the calipers, to avoid contacting the spindle’s housing. (Figure 8)
14. Grease the caliper slide pins and secure the mounting bolts to the appropriate torque.
15. Fasten brake hoses and be sure to put the copper washers on both sides of the banjo bolt fittings.
16. Using an assistant, turn the steering wheel lock to lock so you can see if there is any interference of steering components and flexible brake hoses. Bleeding order is rear passenger, rear driver, front passenger, front driver. Repeat.
17. Bleed the brakes, and when done use brake cleaner to make sure that the rotors are clean and ready for use. They should be chemical free.
18. Mount wheels and torque down lug nuts.
19. Remove the jack stands and slowly let down the vehicle and inspect for any clearance problems.
20. With the vehicle back on the ground, turn the steering wheel lock to lock so you can see if there is any interference of steering components and flexible brake hoses.
21. Depress brake pedal and check for brake pressure and response.
22. Re-bleed if necessary.
23. Remember if you are upgrading to discs for the first time, you will need a residual pressure valve for the front, a residual pressure valve for the rear and a proportioning valve. See typical brake system configurations. Get a wheel alignment.

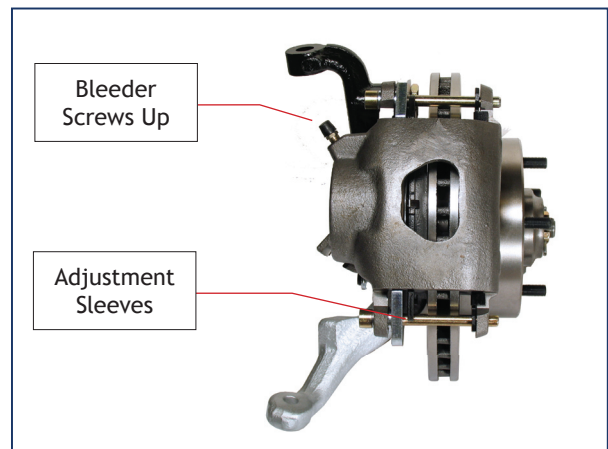

FIGURE. 8

MASTER CYLINDER / POWER BOOSTER INSTALLATION

1. Disconnect the old master cylinder lines (Remember, if operating around painted surfaces, avoid brake fluid to paint contact). Remove any valves that are installed in the drum system and discard. If the vehicle has a pressure differential switch, it must also be removed. Remove the old master cylinder.
2. When changing from a manual brake system to a power system, the clevis assembly that attaches the push rod to the brake pedal must be removed and lowered one inch. If two holes are in the pedal use the lower hole for the power booster rod attachment. If only one hole exists from the manual system a second hole must be drilled one inch lower. Remove the clip and pin that attaches the clevis to the brake pedal and retain them. If the lower hole does not already exist, one must be drilled. Screw the clevis assembly onto the new push rod on the booster about 1/2".
3. Mount the booster to the fire-wall with the existing studs or bolts. Place the clevis assembly into the lower hole in the pedal and install the pin and clip (See Figure 9).
4. Install the proper fitting into the intake manifold for vacuum. Connect the vacuum hose from the engine to the power booster. **YOU WILL NEED AT LEAST 18" VACUUM TO OPERATE A BOOSTER.**
5. Bench bleed the master cylinder with the supplied bleeder kit.
6. Install the master cylinder onto the booster.
7. Flush out the old brake fluid and replace with DOT 4.
8. Bleed the entire system starting at the wheel farthest from the master cylinder. Check the pedal feel for firmness. Adjust the clevis so there is 1/4" free play at the pedal stop. If pedal is spongy, bleed again.

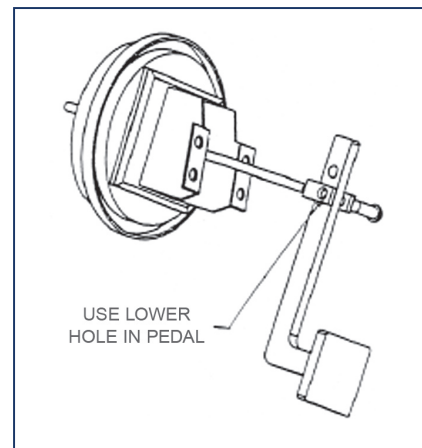

FIGURE 9

NOTE: If you are installing disc brakes without a power booster just mount the manual master to the fire-wall on the two studs that line up with the large hole. Attach the manual brake push rod to the pedal in the upper hole and adjust it so that it seats into the piston hole without applying pressure to the piston while at rest.

PV-2 OR PV-4 PROPORTIONING VALVE

INSTALLATION:

The most common proportioning valve plumbing is shown in Figure 10. An alternative plumbing method is to plug off the top front line and have the bottom front line go to a "T" fitting. From the "T" fitting, the front lines are then split off to the left and right calipers.

TESTING FOR PROPER OPERATION:

1. Use a test light by attaching a clip to a positive contact on the vehicle and touch the point of the tester to the electrical connection of the combination valve. If the light does not come on, the valve system is operation correctly and no further testing is required.
2. If the light does come on, this indicates that the pressure differential valve is stuck in the front or rear position.
3. Bleed the brake system to determine if the front or rear lines are blocked off. Set up one front wheel and one rear wheel for bleeding at the same time. Crack both bleeder screws and gently pump the pedal a few times. The blocked side will trickle fluid out when the bleeder screw is cracked and the pedal pressed. An unblocked line will squirt fluid out the bleeder.

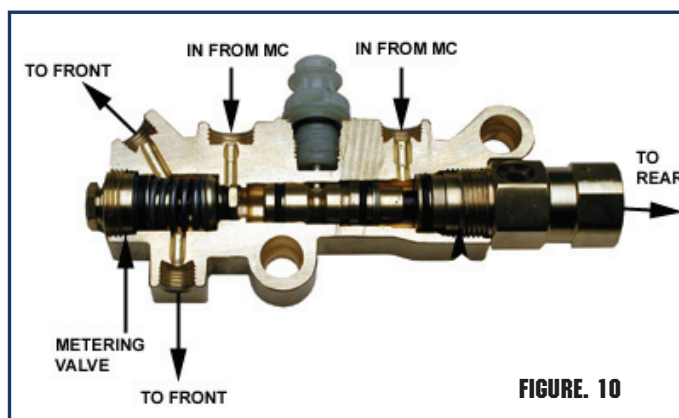

FIGURE 10

4. The lines that are clear must be left open and the blocked lines should have the bleeder screws tight to cause pressure to build up on that side. Be sure to use the standard bleeding procedures to prevent air from entering the system.
5. Slowly press the pedal with steady pressure a number of times until the light goes out; this will center the differential valve. You may also hear a pop come from the proportioning valve. This is the metering valve returning to its equalized position. When the light goes out, close the bleeder screw.

ADJUSTABLE PROPORTIONING VALVE



Adjustable proportioning valves are essentially pressure reducing valves and are often utilized in disc / drum, disc / disc and drum / drum braking systems. The valve is used to control front-to-rear brake pressure bias and will work for all types of vehicles. Install this valve between the distribution block and the rear flex hose in the front-to rear rigid brake line. Always use tube wrenches to tighten fittings properly. Final settings of this valve will depend on your particular vehicle, and individual preference.

SPECIFICATIONS

- “IN” (Stamped on valve) – Rigid brake line from the distribution block to this port. On early cars: the master cylinder rear port to this port.
- “OUT” (Stamped on valve) – Rigid brake line to the rear flex hose.
- “DECREASE” – Reduces the brake line pressure to the rear brakes.
- “INCREASE” – Increases the pressure to the rear brakes.

Maximum pressure regulation: 300 psi. Inlet port of valve: 1/8 – 27 NPT. Standard adaptors: 3/8” – 24 for 3/16” line. Mounting hole diameter: .250” (two).

WHAT TO DO IF YOU SUSPECT YOUR BOOSTER IS NOT WORKING

It is rare that one of our kits will contain a defective power booster but if you suspect that your booster is not functioning correctly perform the following tests:

BASIC TEST

1. With the engine off depress and release the brake pedal several times to eliminate vacuum from the power section.
2. Depress the pedal and hold down with light pressure, 15 to 25 pounds.
3. Start engine.
4. If the power unit is operating the pedal will drop slightly. Less pressure will be needed to hold the pedal down.

IF BOOSTER IS NOT OPERATING (GIVING A VERY HARD PEDAL)

1. Disconnect the vacuum hose from the booster check valve and check the vacuum level at this point with the engine running with a vacuum gauge. You should have at least 18” vacuum to the booster. Anything lower will begin to give a hard pedal. If the vacuum level is below 18” you may be able to tune the engine and bring the vacuum level up to that level. If the vacuum level is around 16” the addition of a vacuum reserve canister will improve the braking. If the vacuum level is below 16” you will need to add an electric vacuum assist pump to supplement the engine vacuum.

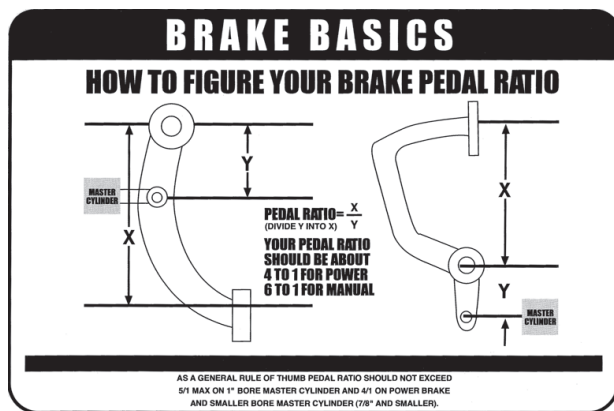

2. If the vacuum level at the check valve is 18" check that the booster check valve is working. Disconnect the vacuum hose at the check valve and attach a piece of tubing. Blow into the valve. If air passes through the valve is defective and must be replaced. Also look into the hose attachment neck on the check valve and be sure there is no obstruction inside the valve.
3. Check your booster for a vacuum leak. With everything hooked up run the engine at moderate speed. Release the accelerator and turn the engine off. Wait 90 seconds and apply the brakes. If the brake applications are power assisted there is no leak. If there is no power assist the booster is defective and must be replaced.

IF THE BOOSTER IS OPERATING BUT YOU STILL HAVE A HARD PEDAL

1. Your combination valve may have tripped shutting off fluid flow to the front or rear brakes. This condition will produce a very hard pedal. Check that fluid passes through the valve to both the front and rear by cracking a bleeder screw and observing a good flow of fluid. If one half of the system does not have flow, re-center the valve.
2. You may have frozen rear wheel cylinders or frozen caliper pistons. If these components freeze you can get a very hard pedal.
3. Your pedal ratio may be too low. Check your pedal ratio. The pedal ratio must be in between 4:1 to 5:1. Some of the older cars that had power brakes used a ratio of almost 1:1. If you add a vacuum booster to this type of car you will have a very hard pedal. Typically we are talking about late 50's cars. Adjust ratio as necessary.
4. Your booster may be undersized for the weight of the vehicle or the bore size of the master. If you try to use a small diameter booster such as a 7" street rod booster for a heavy car you will get a very hard pedal. Compounding the problem is an attempt to use a large bore master (1-1/4" or larger) on a small booster.

IF YOUR BRAKE PEDAL IS VERY SENSITIVE AND THE BRAKES GRAB

1. Your pedal ratio may be too high. Power brakes will require a 4:1 to 5:1 ratio. If your ratio is around 6:1 you are getting too much mechanical advantage making the brakes extremely sensitive. Adjust the ratio to correct level.
2. The booster may be too large for the weight of the vehicle. Lightweight vehicles with large boosters give you "touchy brakes". This effect may be dampened somewhat by going to a larger bore master.
3. Too large a booster for front drum brakes. Drum brakes do not require as much pressure as disc brakes (500 psi vs. 1,000 psi). If your booster is very large (11") and you have drum brakes you are over-boosted. Do a pressure test to determine what you have.
4. The booster has a cracked internal hub. When there is a crack in the phenolic hub inside the booster it will be either totally on or totally off. Any slight pressure to the pedal will cause the brakes to lock up. The booster must be replaced.

TEN REASONS FOR A POOR BRAKE PEDAL

CAUSE	REASON
Bleeder screws on calipers not on top.	The bleeder screws on calipers must be at the 12:00 position on the caliper to allow all the air to escape during bleeding. A very common mistake installers will make is to reverse the side the caliper goes on giving you a situation where the caliper bleeder screw is facing down. It's also common to use the wrong caliper on a bolt on disc kit giving a situation where the bleeder hole is shifted from the 12:00 position producing a pocket of air at the top of the caliper bore which can not be dislodged. Check your bleeder hole orientation.
A defective master cylinder which does not hold pressure.	If brake fluid bypasses a pressure seal on a master cylinder you will get a pedal that fades. To test for this obtain two inverted flare plugs at an auto parts store and plug both master cylinder outlets. Try your pedal. If the pedal is high and firm the master is good. If the pedal fades the master is bad. Replace master as necessary.
No residual pressure valve to rear drums.	Drum brakes require the use of a 10 Ib residual pressure valve in the line. This residual pressure counter balances the drum brake spring tension keeping the shoes close to the drums. This results in a higher firmer pedal. You can test this by clamping off the rear hose removing the rear drums from the system. Now test your pedal. If the pedal gets better you will need to splice a 10 Ib residual pressure valve into the rear line.
Hard line that loops up.	Hard brake line that loops up and then back down will tend to trap air. It doesn't take much air to cause problems so check your lines carefully.
Incorrect master cylinder.	If the bore size of the master cylinder is too small for the fluid requirements of the system you will get a very poor pedal. This will happen most frequently with four piston calipers and with four wheel disc brakes. The only solution for this is to install a larger bore master cylinder or a true four wheel disc master.
Incorrectly bled or adjusted rear calipers.	Rear calipers that have an internal parking brake with a lever can be troublesome. These calipers must be adjusted so that the piston is moved out and the pads are close to the rotor. If this initial adjustment is not made the pistons will travel outward during activation but no squeezing of the rotor will occur. This can be checked by clamping off the rear hoses and checking if the pedal gets better. Adjust as necessary.
Incorrect booster pin length.	The booster pin that pushes on the master cylinder must almost be touching the master cylinder piston face. A gap larger than 1/32" will begin to introduce a spongy pedal. Adjust as necessary.
Silicone brake fluid.	While silicone fluid is great because it does not attack paint it also aerates very easily and can give a spongy pedal.
Rear wheel cylinders too large.	Rear drum wheel cylinders that are too large will give a poor pedal. Check as in step six above.
Loose front wheel bearings.	Loose front wheel bearings will cause rotor wobble. This will cause the caliper pistons to retract too far into the caliper giving a spongy pedal every time you hit the brakes. Check and adjust as necessary.

UNIVERSAL FRONT DISC BRAKE CHECKLIST

	Spindle properly secured to ball joints and tie rods with castle nut and cotter pin.
	All mounting bolts properly tightened.
	Wheel bearings properly packed with grease.
	Inner bearing must be installed before grease seal.
	Rotor I bearings slide onto spindle with ease.
	Washer, castle nut properly torqued and cotter pin installed.
	Calipers installed and properly torqued.
	Spin rotor and check for any interference. (If any interference is found, resolve problem before driving vehicle.)
	Flex lines are properly installed with no interference.
	Power booster (if applicable) installed properly.
	Master cylinder bench bled according to the instructions.
	All brake lines are properly tightened and free of leaks.
	Turn wheels lock to lock and check for any interference.
	Place wheel onto vehicle and spin the wheel to make sure there is no interference between the brakes and wheel.

UNIVERSAL REAR DISC BRAKE CHECKLIST

	All bolts on base bracket properly tightened.
	All caliper mounting bolts properly tightened.
	Rotor slides onto axle with ease.
	No interference with rotor and any other parts (splash shield, brackets, etc.).
	Caliper is centered over the rotor (because of difference in axle lengths, you may have to shim caliper in or out).
	No interference with caliper and rotor.
	All brake lines are tight with no leaks.
	Parking brake is properly adjusted and not dragging, with vehicle on ground.
	Adjustable proportioning valve installed (if applicable).
	Distribution block modification made (if applicable).
	Brake system properly bled.

IMPORTANT WITH EVERY NEW SET OF ROTORS AND PADS, YOU SHOULD GIVE YOUR VEHICLE 200 - 250 MILES OF EASY DRIVING TO PROPERLY SEAT THE PADS TO THE ROTORS. DO NOT TAKE THE VEHICLE UP TO 60 MPH AND JAM ON THE BRAKES BEFORE THE FIRST 200 - 250 MILE BREAK IN PERIOD IS OVER, OR YOU WILL GLAZE THE PADS AND ROTORS.